

ITEM	QTY.	PART NUMBER	DESCRIPTION
1	0.5	3511	Enforcer hose, 1 1/4" EPDM
2	1	3EL10012	Hose Adapter, 90 deg, 1" MPT x 1/2"
3	1	3EL10034	Hose adapter, 90°, 1" MPT x 3/4" barb
4	2	6824052	Hose clamp 3/4" - 1 3/4", stainless
5	2	F1529A	Foamer Mixing Chamber, Pad, Open Cell Poly Foam (Black)
6	1	F1529B	Foamer Mixing Chamber, Pad, Closed Cell Foam (White)
7	1	F506	Mixing chamber sponge

NOTE:

- CUT HOSE TO LENGTH AS NOTED.
- PLACE FOAM DISKS (ITEMS 5 & 6) AND SPONGE (ITEM 7).
- CLAMP HOSE ONTO FITTINGS (USE PIPE SEALANT AND TAPE ON THREADS).

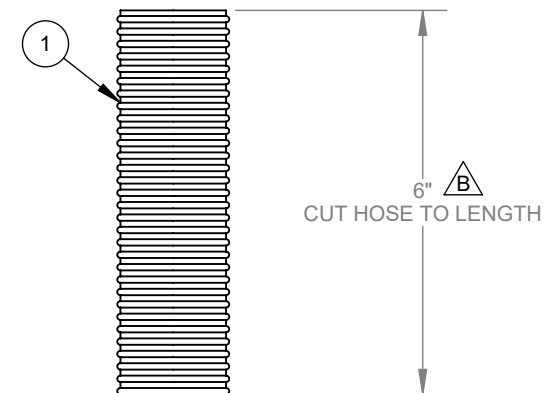

REVISIONS			
REV.	DESCRIPTION	DATE	APPROVED
A	DRAWN	8/10/2021	AM
B	CHANGED HOSE LENGTH FROM 8" TO 6".	11/28/2023	AM

UNLESS OTHERWISE SPECIFIED:
 DIMENSIONS ARE IN INCHES
 TOLERANCES:
 FRACTIONAL: ±1/8
 ANGULAR: PRESS ±0.5 BEND ±2
 ONE PLACE DECIMAL ±0.06
 TWO PLACE DECIMAL ±0.03
 THREE PLACE DECIMAL ±0.01



295 Wood Corner
 Rd. Lititz, PA 17543
 www.pbzmf.com

DESCRIPTION:
Foamer Mixing Chamber

	NAME	DATE
LAST SAVED	anthonym1	8/10/2021
MODELED	Anthony Martin	8/3/2021

PROPRIETARY AND CONFIDENTIAL
 THE INFORMATION CONTAINED IN THIS DRAWING IS THE SOLE PROPERTY OF PBZ, LLC. ANY REPRODUCTION IN PART OR AS A WHOLE WITHOUT THE WRITTEN PERMISSION OF PBZ, LLC IS PROHIBITED.

MATERIAL	SIZE	PART NO.	REV
FIXTURE	B	F1529	B

DO NOT SCALE DRAWING SCALE: 1:3 SA: 152.96 sq in WEIGHT: 0.47 lbs SHEET 1 OF 1